

FAG

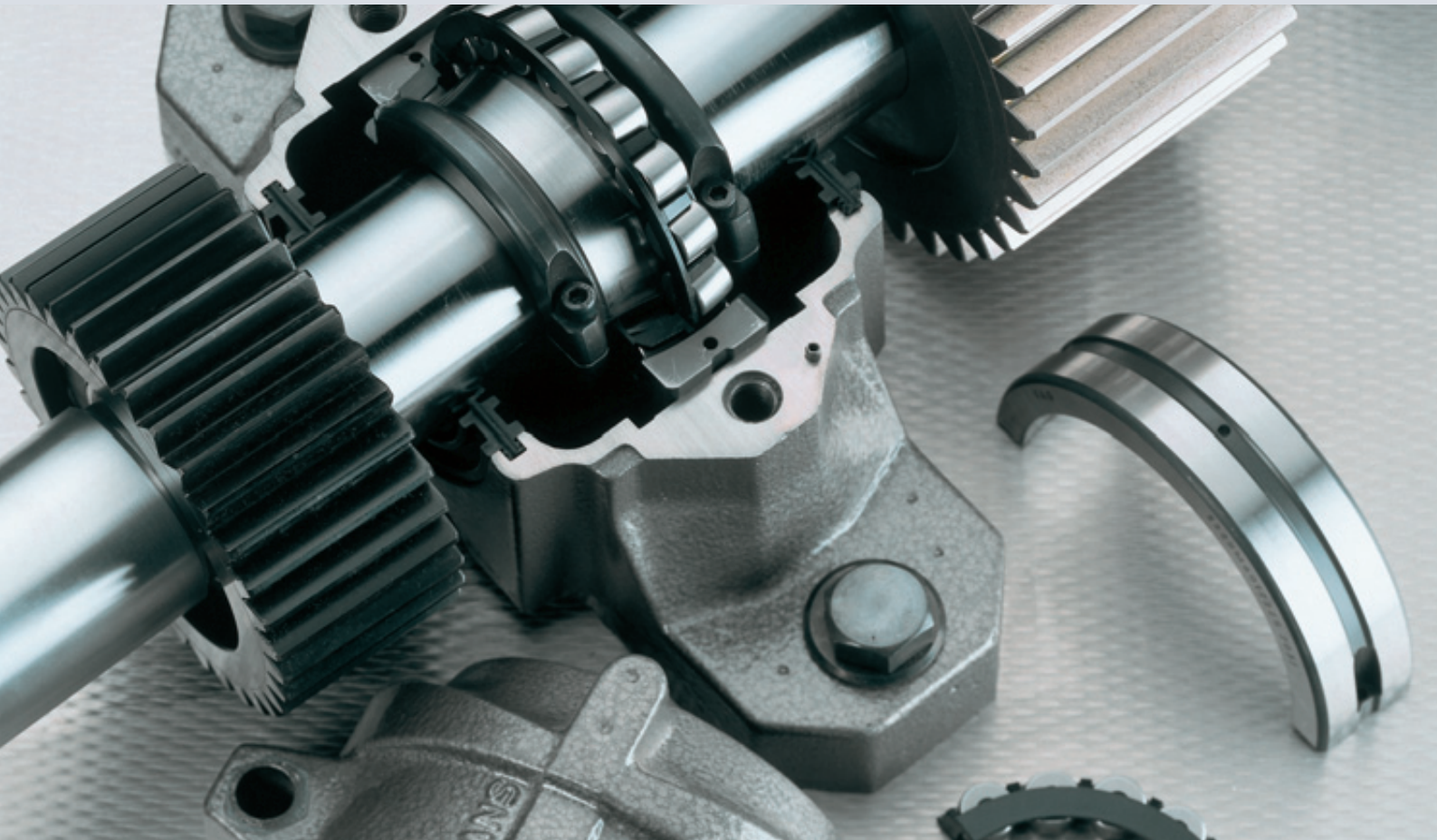

FAG Split spherical roller bearings

**Saving cost by rapid bearing replacement
at locations of restricted access**

A Member of the
Schaeffler Group

Saving cost by rapid bearing replacement
at locations of restricted access

FAG Split Spherical Roller Bearings

Publ. No. WL 43 165 EA

FAG Kugelfischer AG

Postfach 1260 · D-97419 Schweinfurt
Phone +49 9721 91-0 · Telefax +49 9721 913435
<http://www.fag.com>

Preface

FAG Kugelfischer AG supplies rolling bearings, accessories and services to original equipment customers in the machine and plant construction sector as well as customers in the distribution and replacement sector. Broad rolling bearing know-how, competent advice for specific applications and extensive customer service for more operational reliability make FAG an indispensable partner to its customers. The development and progressive development of our products is based on the requirements of their future operation in the field. Ideally, the outline of requirements is drawn up jointly by our researchers and application engineers in cooperation with the machine manufacturers and operators. This forms the basis for convincing solutions both technically and economically speaking.

Our production sites are situated in Germany, Italy, Portugal, Korea, the USA and India. Marketing is effected through a network of subsidiaries and business partners spanning almost the whole world.



Time-saving bearing replacement	4
Cost reduction	4
Ranges of application	4
Fitting into split plummer block housings	4
Bearing design	6
Load carrying capacity	7
High-speed suitability	7
Fits	7
Lubrication	7
Split spherical roller bearings in metric dimensions	8
Split spherical roller bearings in inch dimensions	16
Cost reduction due to shorter downtimes	26

Time-saving bearing replacement · Cost reduction · Ranges of application · Fitting into split plummer block housings

Time-saving bearing replacement at locations of restricted access

Split spherical roller bearings are mainly used for applications where the replacement of an unsplit spherical roller bearing would require intricate additional work, e.g. where gearwheels or couplings have to be withdrawn, drives dismounted, and shaftings disassembled. With split spherical roller bearings the downtimes of machines and plants is reduced and thus the production cost as well.

Cost reduction

Calculation examples on pages 26 and 27 show the extent of cost reduction which can be achieved by using split spherical roller bearings instead of unsplit ones. In one case the cost reduction amounts to about € 42,000, in the other one even to about € 220,000. We have

provided a form on page 28 which you may use to draw up a similar cost comparison for one of your applications. The filled-in form is a useful basis for talks with our service engineers.

With new constructions split spherical roller bearings help in many cases to save considerable cost since they simplify the assembly and facilitate mounting.

Ranges of application

Applications range from shafts supported by several bearings to bearing locations of restricted access, for example:

- belt drives
- ships
- conveyor plants
- rolling mills
- ventilation systems
- paper machines

Replacement bearings for spherical roller bearings with adapter sleeve

The dimensions of FAG split spherical roller bearings were adapted so that they can be used instead of unsplit spherical roller bearings and their adapter sleeves.

Outside diameter, outer ring width and shaft seat diameter are identical.

Fitting into split plummer block housings

FAG split spherical roller bearings can be mounted into FAG split plummer block housings without requiring any further machining of the housings. The same applies to housings from other manufacturers provided that the internal dimensions are identical.

Conveyor plant drive unit



Ventilator drive unit



Time-saving bearing replacement · Fitting into split plummer block housings

1: Easy bearing replacement as split spherical roller bearings (top) require the same mounting space as unsplit bearings with adapter sleeves (bottom).

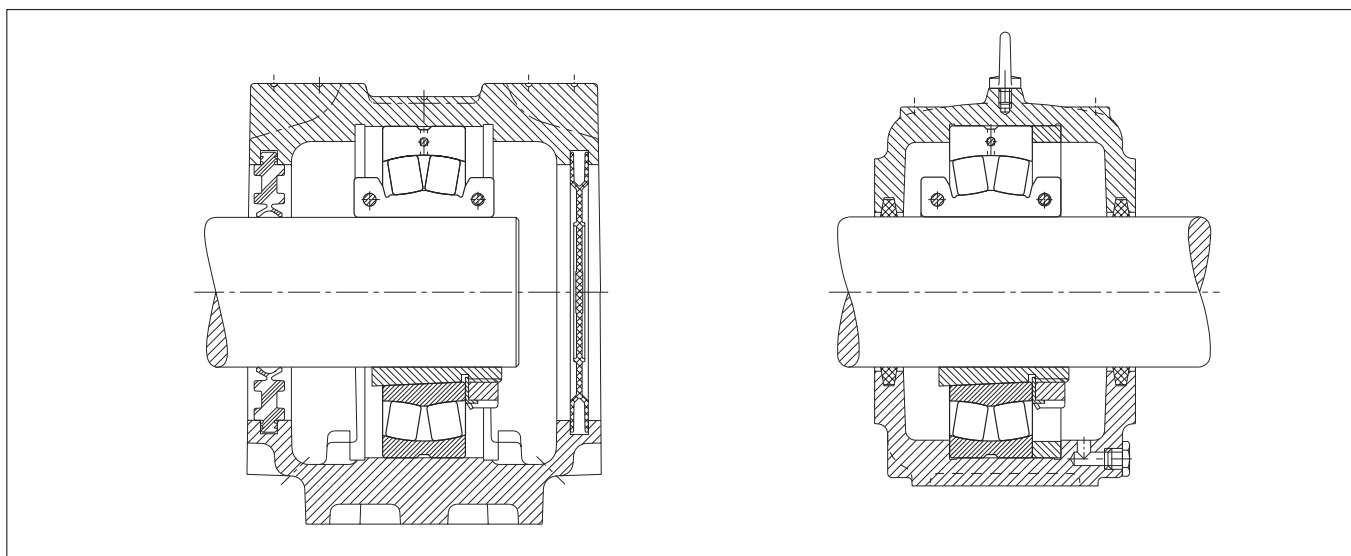

2: Easy to inspect, fast and easy mounting – the FAG split spherical roller bearing directly before mounting into an SNV housing.



Bearing design

FAG split spherical roller bearings have a cylindrical bore. Inner ring, outer ring and roller/cage assembly are split into halves. The split bearing rings are bolted together.

The internal design of the split spherical roller bearings was adapted from the well-proven spherical roller bearings of design E so that the bearings have maximum load carrying capacity.

The bearings are equipped either with a split moulded cage of glass-fibre rein-

forced polyamide (suitability for high temperatures, see FAG catalogue WL 41 520) or with a split machined brass cage.

Split spherical roller bearings have the normal tolerances of unsplit radial bearings and the normal clearance of unsplit spherical roller bearings with a cylindrical bore (DIN 620).

In this publication the standard design of split spherical roller bearings is de-

scribed where the locking rings are integrated in the inner rings. FAG split spherical roller bearings with separate locking rings are recommended for applications where considerable temperature differences between shaft and inner ring halves may have to be accommodated, e.g. dryer rolls of paper machines. Information on this special design will be supplied by FAG on request (cp. FAG video "The Installation of Split Spherical Roller Bearings in the Dryer Section of a Paper Mill").

3: The internal design corresponds to the well-proven E design.

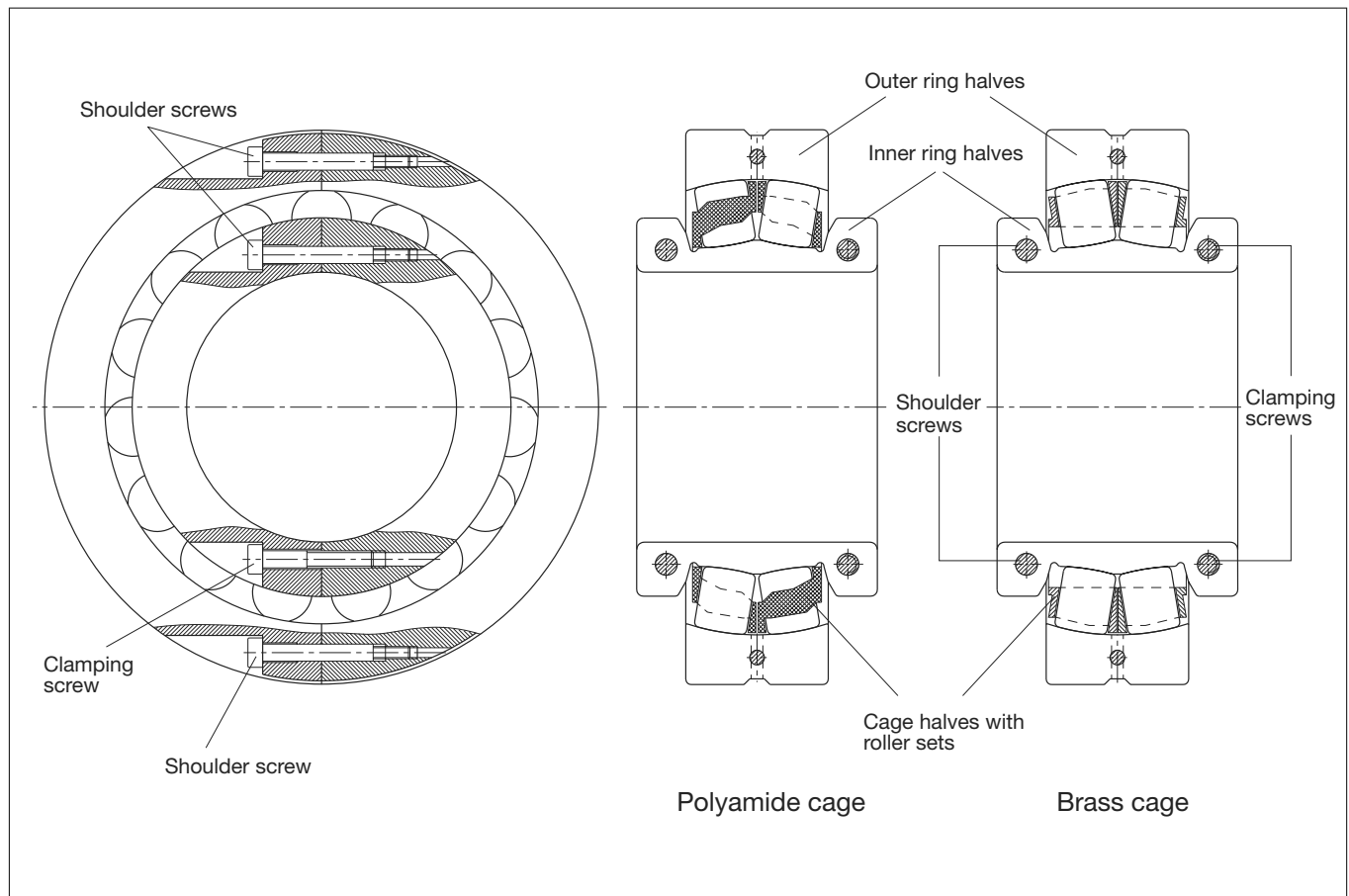

Load carrying capacity

The load carrying capacity of split spherical roller bearings is smaller than that of unsplit spherical roller bearings since the pitch circle for the roller/cage assembly is reduced due to the outer ring bolting. Nevertheless, a high load carrying capacity is achieved by providing the largest possible number of rollers with the largest possible diameter (E design).

Cycling of the separating joint is taken into consideration in calculating the equivalent dynamic load by the impact factor 1.1.

Bearing dimensioning is effected in accordance with the usual calculation procedure indicated in FAG catalogue WL 41 520.

High-speed suitability

The bearing tables indicate the limiting speeds. These values take into account the cage strength and the vibrations caused by cycling of the separating joints.

In cases where the limiting speeds are exceeded FAG Application Engineering must be consulted.

Fits

The shaft has to be machined to h6...h9 in order to attain the required tight inner ring fit after bolting. These shaft tolerances are also used for unsplit bearings mounted with adapter sleeves. Usually, the housing bore is machined to H7 or H8.

Lubrication

FAG split spherical roller bearings are usually lubricated with a lithium soap base grease of penetration class 2 with EP additives. The lubrication intervals are identical with those of unsplit bearings.

Split spherical roller bearings may be relubricated via a groove and holes in the outer ring.

FAG spherical roller bearings

split, in metric dimensions

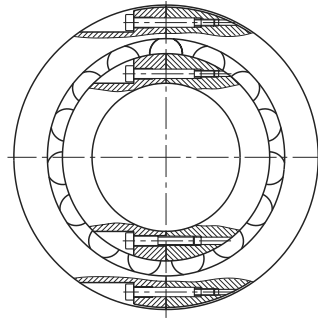

Suffix:

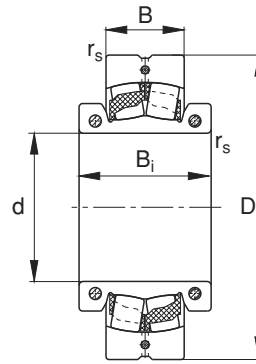

Moulded polyamide cage
T

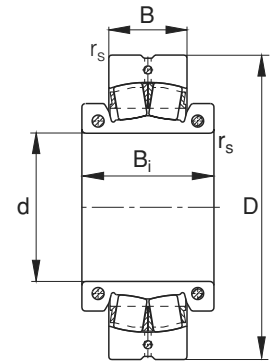

Machined brass cage
MA

Shaft	Dimensions					Load rating · Factor dyn.						Mass ≈ kg	Permissible axial load*) kN	Limiting speed min ⁻¹
	d	D	B	B _i	r _s min	C	e	Y	Y	stat. C ₀	Y ₀			
	mm					kN		F _a /F _r ≤ e	F _a /F _r > e	kN				
55	55	110	28	52	1.5	120	0.23	2.9	4.4	146	2.9	1.47	5.4	3000
60	60	120	31	55	1.5	143	0.24	2.8	4.2	166	2.8	1.8	5.4	2800
65	65	130	31	60	1.5	173	0.24	2.8	4.2	208	2.8	2.33	5.4	2400
70	70	140	33	62	2	180	0.23	3	4.4	228	2.9	2.95	5.4	2400
75	75	150	36	68	2	183	0.22	3.1	4.6	236	3	3.25	7.6	2200
80	80	160	40	70	2	212	0.22	3.1	4.7	270	3.1	4.28	7.6	2000
85	85	170	43	74	2	260	0.22	3	4.5	325	3	5.11	7.6	1900
90	90	180	46	76	2.1	285	0.23	2.9	4.3	360	2.8	6.02	7.6	1700
100	100	180	56	90	2	310	0.28	2.4	3.5	430	2.3	8	7.6	1100
	100	200	53	92	2.1	360	0.24	2.8	4.2	465	2.8	8.88	13.8	1500
110	110	180	46	86	2	270	0.23	2.9	4.3	390	2.8	7	7.6	1100
	110	200	62	102	2	390	0.28	2.4	3.6	570	2.3	9.55	14	1000
	110	215	58	98	2.1	455	0.25	2.7	4	585	2.7	10.6	13.8	1300
115	115	200	52	90	2	305	0.22	3	4.5	455	3	9.5	7.6	1100
	115	210	64	104	2	490	0.28	2.4	3.6	710	2.3	11.2	7.6	900
	115	230	64	104	3	540	0.25	2.7	4	720	2.7	14.3	13.8	1200
125	125	210	53	94	2	390	0.23	3	4.4	600	2.9	10	7.6	950
	125	225	68	110	2.1	510	0.28	2.5	3.6	750	2.4	13.5	13.8	850
	125	250	68	110	3	630	0.26	2.6	3.9	880	2.6	17.9	13.8	1100

The designs printed in **bold face** are produced in series.
Information on other designs will be supplied on request.

*) For inner rings which are not axially supported.

Equivalent dynamic load		Equivalent static load	
$P = 1.1 (F_r + Y \cdot F_a)$	[kN]	$F_a/F_r \leq e$	$P_0 = F_r + Y_0 \cdot F_a$ [kN]
$P = 1.1 (0.67 \cdot F_r + Y \cdot F_a)$	[kN]	$F_a/F_r > e$	

P/C must be equal to or less than 0.2 to prevent the inner rings from creeping on the shaft in circumferential direction. Higher values are permissible if the speed is much lower than the limiting speed. Please consult our experts in such cases.

Examples for bearing exchange in plummer block housings

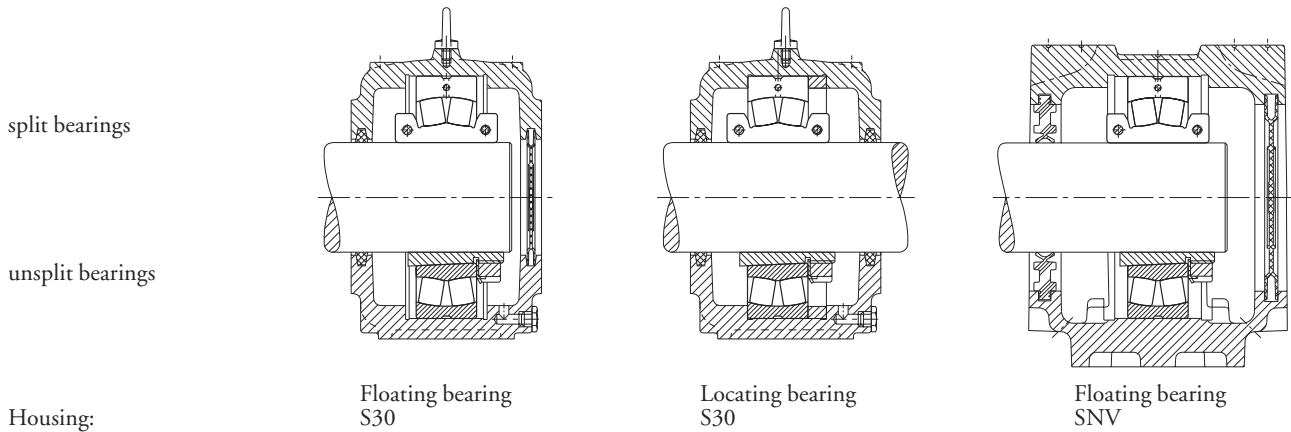

Bolt tightening torque		Code		Can replace unsplit spherical roller bearings with adapter sleeve	Matching plummer block housings**)	
Inner ring M_i N m	Outer ring M_a N m	Bearing FAG	Bearing FAG	Bearing	Adapter sleeve	FAG
8.5	1.5	222SM55T		22212K	H312	SNV110
8.5	4	222SM60T		22213K	H313	SNV120
8.5	4	222SM65T		22215K	H315	SNV130
8.5	4	222SM70T		22216K	H316	SNV140
14	8.5	222SM75T		22217K	H317	SNV150
14	8.5	222SM80T		22218K	H318	SNV160
14	8.5	222SM85T		22219K	H319	SNV170
14	14	222SM90T		22220K	H320	SNV180
14 35	4 14	222SM100T	231SM100MA	23122K 22222K	H3122 H322	- SNV200
14 35 35	4 8 14	222SM110T	230SM110MA 231SM110MA	23024K 23124K 22224K	H3024 H3124 H3124	S3024K - SNV215 ¹⁾
14 14 35	8.5 4 14	222SM115T	230SM115MA 231SM115MA	23026K 23126K 22226K	H3026 H3126 H3126	S3026K - SNV230 ¹⁾
14 35 35	4 8 14	222SM125T	230SM125MA 231SM125MA	23028K 23128K 22228K	H3028 H3128 H3128	S3028K - SNV250 ¹⁾

**) The bearings also fit into housings from other manufacturers provided the inside dimensions are the same. Seals, covers and locating rings for SNV housings, see FAG catalogue WL 41 520

¹⁾ Housing with eye bolt

FAG spherical roller bearings

split, in metric dimensions

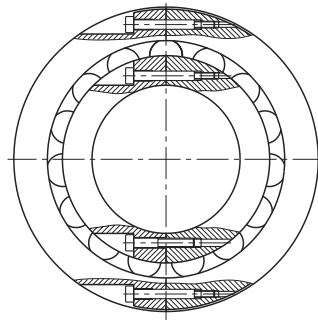

Suffix:

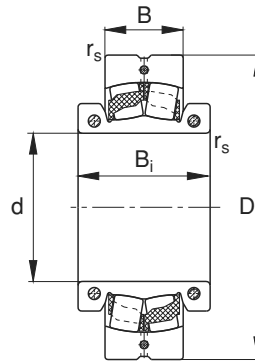

Moulded polyamide cage
T

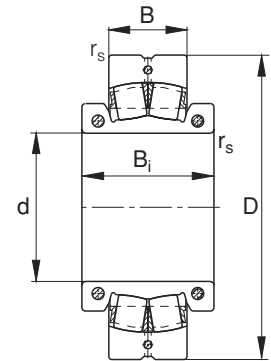

Machined brass cage
MA

Shaft	Dimensions					Load rating · Factor						Mass ≈ kg	Permissible axial load*) kN	Limiting speed min ⁻¹
	d	D	B	B _i	r _s min	dyn.			stat.					
	mm					C	e	Y	Y	C ₀	Y ₀			
						kN		F _a /F _r ≤ e	F _a /F _r > e	kN				
135	135	225	56	100	2.1	405	0.22	3.1	4.6	620	3	13	13.8	950
	135	250	80	123	2.1	570	0.27	2.5	3.7	850	2.4	19.5	22.2	800
	135	270	73	122	3	735	0.25	2.7	4	1020	2.6	24.1	22.2	1000
140	140	240	60	106	2.1	450	0.22	3.1	4.6	680	3	15.5	13.8	900
	140	270	86	135	2.1	710	0.29	2.3	3.5	1040	2.3	25.8	22	700
	140	290	80	124	3	850	0.25	2.7	4	1200	2.6	28.5	22.2	950
150	150	260	67	112	2.1	510	0.22	3.1	4.6	800	3	20.5	13.8	800
	150	280	88	133	2.1	710	0.29	2.3	3.5	1040	2.3	26.4	22	700
	150	310	86	128	4	965	0.26	2.6	3.9	1370	2.6	35.6	22.2	900
160	160	280	74	123	2.1	640	0.23	3	4.4	1000	2.9	25.5	22.2	750
	160	300	96	140	2.1	830	0.29	2.3	3.5	1220	2.3	32.7	22	670
	160	320	86	131	4	965	0.26	2.6	3.9	1370	2.6	37.6	22.2	900
170	170	290	75	120	2.1	780	0.23	2.9	4.3	1250	2.8	23.6	22.2	700
	170	320	104	142	2.1	915	0.28	2.4	3.5	1430	2.3	40.6	22	630
	170	340	92	142	4	1140	0.25	2.7	4	1630	2.7	43.6	22.2	800
180	180	310	82	134	2.1	800	0.23	3	4.4	1270	2.9	35	22	670
	180	340	112	160	3	1020	0.29	2.3	3.5	1530	2.3	48.4	22	600
	180	360	98	154	4	1140	0.25	2.7	4	1630	2.7	52.7	22.2	600
200	200	340	90	136	3	965	0.23	2.9	4.3	1530	2.8	37.2	22	630
	200	370	120	175	4	1320	0.31	2.2	3.3	2040	2.2	61.8	32	530
	200	400	108	162	4	1340	0.25	2.7	4	1900	2.6	69.6	32	560
220	220	360	92	156	3	1100	0.23	2.9	4.3	1830	2.8	53	32	560
	220	400	128	190	4	1630	0.3	2.3	3.3	2600	2.2	86	32	480
	220	440	120	170	4	1460	0.25	2.7	4	2080	2.7	89.3	32	500

The designs printed in **bold face** are produced in series.
Information on other designs will be supplied on request.

*) For inner rings which are not axially supported.

Equivalent dynamic load		Equivalent static load	
$P = 1.1 (F_r + Y \cdot F_a)$	[kN]	$F_a/F_r \leq e$	$P_0 = F_r + Y_0 \cdot F_a$ [kN]
$P = 1.1 (0.67 \cdot F_r + Y \cdot F_a)$	[kN]	$F_a/F_r > e$	

P/C must be equal to or less than 0.2 to prevent the inner rings from creeping on the shaft in circumferential direction. Higher values are permissible if the speed is much lower than the limiting speed. Please consult our experts in such cases.

Examples for bearing exchange in plummer block housings

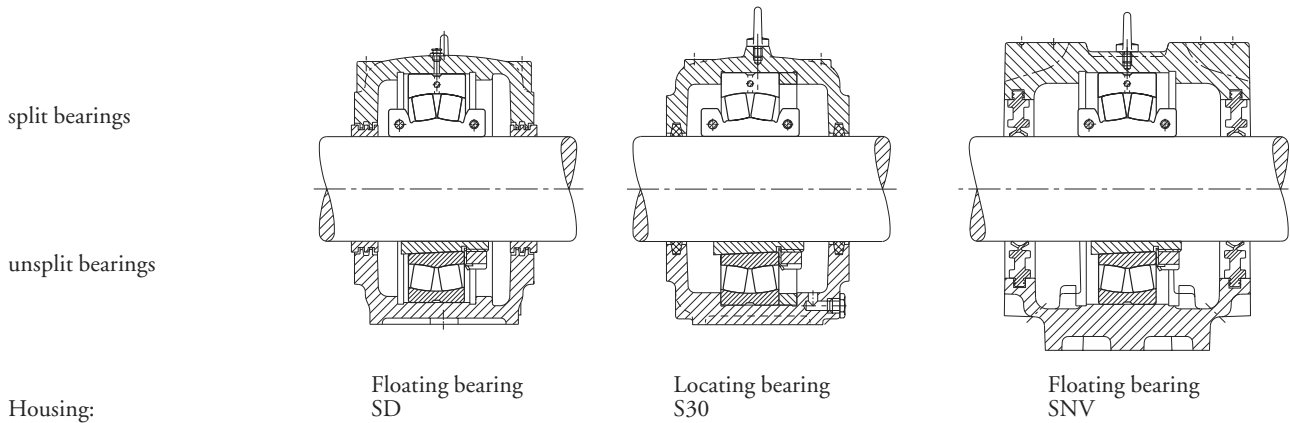

Bolt tightening torque		Code	Can replace unsplit spherical roller bearings with adapter sleeve		Matching plummer block housings**)	
Inner ring M_i N m	Outer ring M_a N m	Bearing FAG	FAG	Bearing	Adapter sleeve	FAG
35	8.5	222SM135T	230SM135MA	23030K	H3030	S3030K
69	14		231SM135MA	23130K	H3130	-
69	35			22230K	H3130	SNV270
35	8.5	222SM140T	230SM140MA	23032K	H3032	S3032K
69	14		231SM140MA	23132K	H3132	-
69	35			22232K	H3132	SNV290
35	8.5	222SM150T	230SM150MA	23034K	H3034	S3034K
69	35		231SM150MA	23134K	H3134	SD3134TS
69	35			22234K	H3134	SD534
69	14	222SM160T	230SM160MA	23036K	H3036	S3036K
69	35		231SM160MA	23136K	H3136	SD3136TS
69	35			22236K	H3136	SD536
69	14	222SM170T	230SM170MA	23038K	H3038	S3038K
69	35		231SM170MA	23138K	H3138	SD3138TS
69	35			22238K	H3138	SD538
69	14		230SM180MA	23040K	H3040	S3040K
69	35		231SM180MA	23140K	H3140	SD3140TS
69	35		222SM180MA	22240K	H3140	SD540
69	35		230SM200MA	23044K	H3044X	S3044K
120	69		231SM200MA	23144K	H3144X	SD3144TS
120	69		222SM200MA	22244K	H3144X	SD544
120	35		230SM220MA	23048K	H3048	S3048K
120	69		231SM220MA	23148K	H3148X	SD3148TS
120	69		222SM220MA	22248K	H3148X	SD548

**) The bearings also fit into housings from other manufacturers provided the inside dimensions are the same. Seals, covers and locating rings for SNV housings, see FAG catalogue WL 41 520

FAG spherical roller bearings

split, in metric dimensions

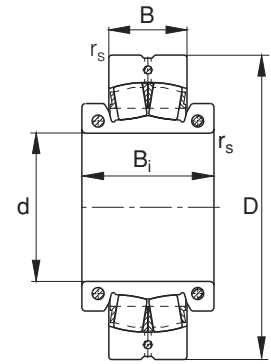
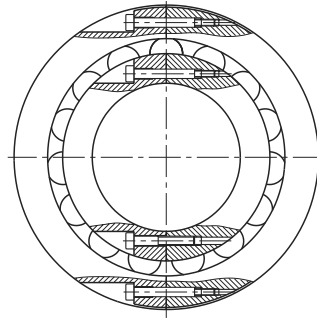

Suffix:

Machined brass cage
MA

Shaft	Dimensions					Load rating · Factor						Mass ≈ kg	Permissible axial load*)	Limiting speed min ⁻¹
	d	D	B	B _i	r _s min	dyn.		stat.		C ₀	Y ₀			
	mm					C	e	Y	Y	C ₀	Y ₀		kN	min ⁻¹
						kN		F _a /F _r ≤ e	F _a /F _r > e	kN				
240	240	400	104	160	4	1220	0.22	3	4.5	2120	3	57.4	32	560
	240	440	144	210	4	1860	0.3	2.3	3.4	3050	2.2	114	32	450
	240	480	130	200	5	1860	0.26	2.6	3.9	2600	2.6	136	60	450
260	260	420	106	170	4	1460	0.23	2.9	4.4	2450	2.9	63.2	32	500
	260	460	146	190	5	2280	0.3	2.2	3.3	3800	2.2	110	32	400
	260	500	130	200	5	2200	0.25	2.7	4	3100	2.6	143	60	430
280	280	460	118	176	4	1600	0.22	3	4.5	2800	3	95	32	480
	280	500	160	218	5	2320	0.29	2.3	3.5	3900	2.3	160	44	400
	280	540	140	200	5	2400	0.24	2.8	4.2	3550	2.7	175	60	430
300	300	480	121	186	4	1860	0.23	2.9	4.3	3200	2.8	108	32	430
	300	540	176	225	5	2750	0.29	2.3	3.4	4750	2.3	184	60	360
	300	580	150	212	5	2650	0.24	2.8	4.2	4050	2.8	214	60	380
320	320	520	133	200	5	2040	0.22	3	4.5	3650	3	120	32	430
	320	580	190	258	5	3100	0.3	2.3	3.4	5200	2.2	226	60	340
	320	620	165	230	6	3100	0.24	2.8	4.1	4750	2.7	244	60	360
340	340	540	134	205	5	2360	0.22	3	4.5	4150	2.9	150	60	380
	340	600	192	270	5	3900	0.3	2.3	3.3	6800	2.2	277	60	300
	340	650	170	240	6	3450	0.25	2.7	4	5100	2.6	267	60	340
360	360	560	135	218	5	2550	0.22	3.1	4.6	4650	3	165	60	380
	360	620	194	270	5	3900	0.3	2.3	3.4	6950	2.2	292	60	300
380	380	600	148	225	5	2700	0.21	3.2	4.8	5100	3.1	187	60	380
	380	650	200	270	6	4050	0.28	2.4	3.6	7200	2.3	326	60	300

The designs printed in **bold face** are produced in series.
Information on other designs will be supplied on request.

*) For inner rings which are not axially supported.

Equivalent dynamic load		Equivalent static load	
$P = 1.1 (F_r + Y \cdot F_a)$	[kN]	$F_a/F_r \leq e$	$P_0 = F_r + Y_0 \cdot F_a$ [kN]
$P = 1.1 (0.67 \cdot F_r + Y \cdot F_a)$	[kN]	$F_a/F_r > e$	

P/C must be equal to or less than 0.2 to prevent the inner rings from creeping on the shaft in circumferential direction. Higher values are permissible if the speed is much lower than the limiting speed. Please consult our experts in such cases.

Examples for bearing exchange in plummer block housings

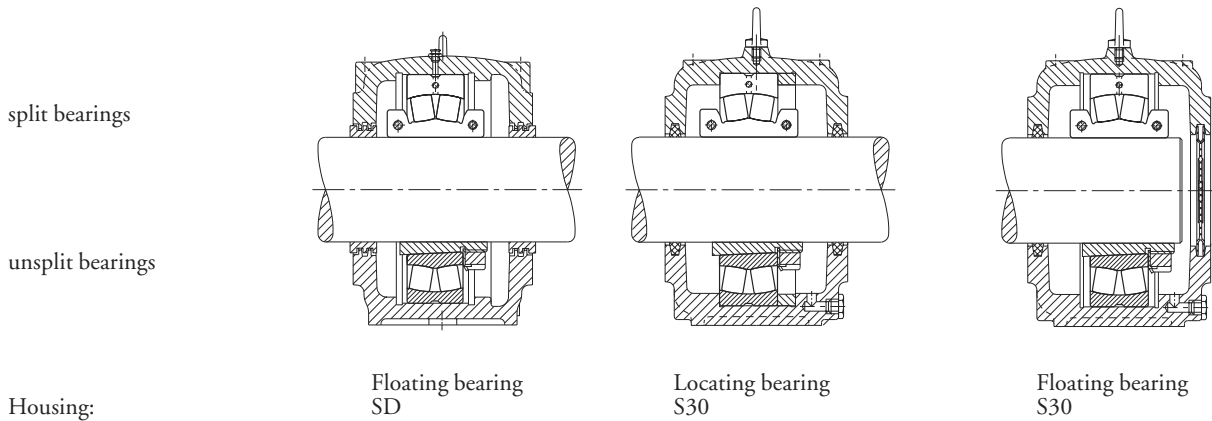

Bolt tightening torque

Code

Can replace unsplit spherical roller bearings with adapter sleeve Matching plummer block housings**)

Inner ring
M_i
N m

Outer ring
M_a
N m

Bearing
FAG

Bearing

Adapter sleeve

FAG

120	69	230SM240MA	23052K	H3052X	S3052K
120	69	231SM240MA	23152K	H3152X	SD3152TS
295	120	222SM240MA	22252K	H3152X	SD552
120	35	230SM260MA	23056K	H3056	S3056K
120	35	231SM260MA	23156K	H3156X	SD3156TS
295	69	222SM260MA	22256K	H3156X	SD556
120	69	230SM280MA	23060K	H3060	S3060K
190	120	231SM280MA	23160K	H3160HG	SD3160TS
295	120	222SM280MA	22260K	H3160HG	SD560
120	69	230SM300MA	23064K	H3064HG	S3064K
295	120	231SM300MA	23164K	H3164HG	SD3164TS
295	120	222SM300MA	22264K	H3164HG	SD564
295	69	230SM320MA	23068K	H3068HG	S3068K
295	190	231SM320MA	23168K	H3168HG	SD3168TS
295	120	222SM320MA			
295	69	230SM340MA	23072K	H3072HG	S3072K
295	69	231SM340MA	23172K	H3172HG	SD3172TS
295	120	222SM340MA			
295	69	230SM360MA	23076K	H3076HG	S3076K
295	69	231SM360MA	23176K	H3176HG	SD3176TS
295	120	230SM380MA	23080K	H3080HG	S3080K
295	120	231SM380MA	23180K	H3180HG	SD3180TS

**) The bearings also fit into housings from other manufacturers provided the inside dimensions are the same.

FAG spherical roller bearings

split, in metric dimensions

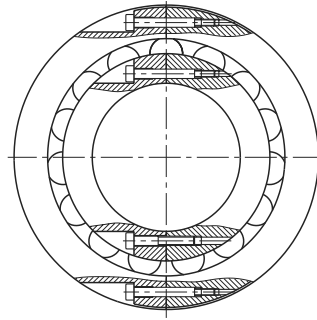

Suffix:

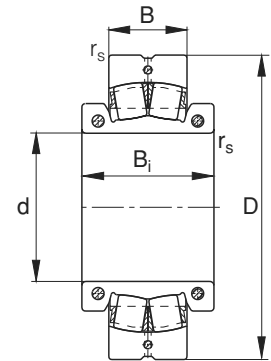

Machined brass cage
MA

Shaft	Dimensions					Load rating · Factor						Mass ≈	Permissible axial load*)	Limiting speed
	d	D	B	B _i	r _s min	C	e	Y	Y	stat.				
	mm					kN		F _a /F _r ≤ e	F _a /F _r > e	C ₀	Y ₀	kg	kN	min ⁻¹
400	400	620	150	225	5	3100	0.22	3.1	4.6	5700	3	214	60	340
	400	700	224	285	6	4400	0.28	2.4	3.6	7650	2.3	366	60	280
410	410	650	157	225	5	3100	0.21	3.2	4.8	5850	3.1	246	60	340
	410	720	226	315	6	5400	0.29	2.3	3.4	9650	2.3	475	94	260
420	420	650	157	235	5	3100	0.21	3.2	4.8	5850	3.1	246	60.5	340

The designs printed in **bold face** are produced in series.
Information on other designs will be supplied on request.

*) For inner rings which are not axially supported.

Equivalent dynamic load			Equivalent static load		
$P = 1.1 (F_r + Y \cdot F_a)$	[kN]	$F_a/F_r \leq e$	$P_0 = F_r + Y_0 \cdot F_a$	[kN]	
$P = 1.1 (0.67 \cdot F_r + Y \cdot F_a)$	[kN]	$F_a/F_r > e$			

P/C must be equal to or less than 0.2 to prevent the inner rings from creeping on the shaft in circumferential direction. Higher values are permissible if the speed is much lower than the limiting speed. Please consult our experts in such cases.

Examples for bearing exchange in plummer block housings

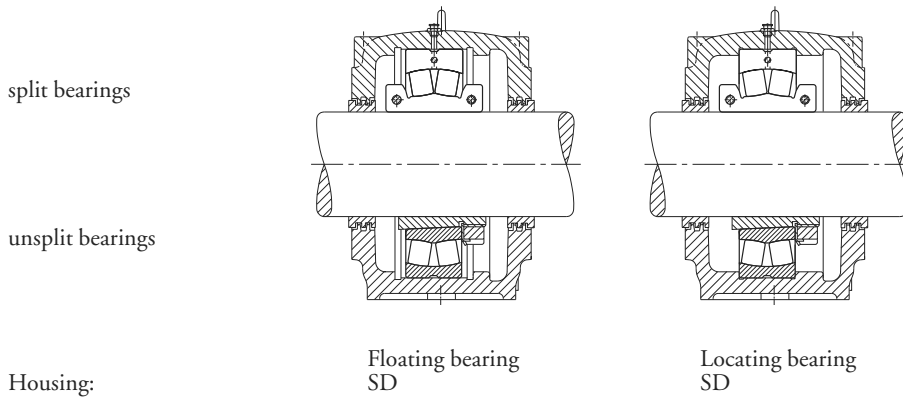

Bolt tightening torque

Code

Can replace unsplit spherical roller bearings with adapter sleeve

Matching plummer block housings**)

Inner ring
M_i
N m

Outer ring
M_a
N m

Bearing
FAG

Bearing Adapter sleeve

FAG

295
295

69
190

230SM400MA
231SM400MA

23084K
23184K

H3084XHG
H3184HG

S3084K
SD3184TS

295
500

120
120

230SM410MA
231SM410MA

23088K
23188K

H3088HG
H3188HG

S3088K
SD3188TS

295

120

230SM420MA

**) The bearings also fit into housings from other manufacturers provided the inside dimensions are the same.

FAG spherical roller bearings

split, in inch dimensions

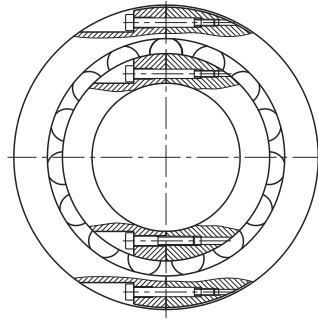

Suffix:

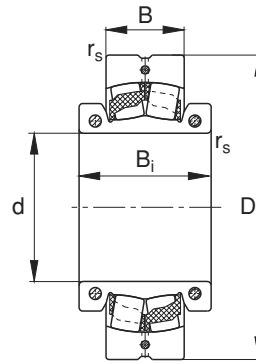

Moulded polyamide cage

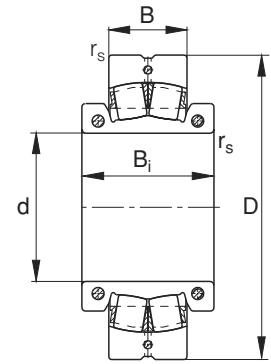

Machined brass cage
MA

Shaft	Dimensions					Load rating · Factor						Mass ≈	Permissible axial load*)	Limiting speed
	d	D	B	B _i	r _s min	C	e	Y	Y	stat.	C ₀			
inch	inch mm					lbs kN	F _a /F _r ≤ e	F _a /F _r > e		lbs kN		lbs kg	lbs kN	min ⁻¹
2 3/16	2.1875 55.563	4.7244 120	1.2205 31	2.1654 55	0.06 1.5	32500 143	0.24	2.8	4.2	37500 166	2.8	4.38 1.99	1200 5.4	2800
2 1/4	2.2500 57.15	4.7244 120	1.2205 31	2.1654 55	0.06 1.5	32500 143	0.24	2.8	4.2	37500 166	2.8	4.37 1.98	1200 5.4	2800
2 7/16	2.4375 61.913	5.1181 130	1.2205 31	2.3622 60	0.06 1.5	39000 173	0.24	2.8	4.2	47500 208	2.8	5.41 2.45	1200 5.4	2400
2 1/2	2.5000 63.5	5.1181 130	1.2205 31	2.3622 60	0.06 1.5	39000 173	0.24	2.8	4.2	47500 208	2.8	5.3 2.41	1200 5.4	2400
2 11/16	2.6875 68.263	5.5118 140	1.2992 33	2.4409 62	0.08 2	40500 180	0.23	3	4.4	51000 228	2.9	6.61 3	1200 5.4	2400
2 15/16	2.9375 74.613	5.9055 150	1.4173 36	2.6772 68	0.08 2	41500 183	0.22	3.1	4.6	53000 236	3	7.89 3.58	1700 7.6	2200
3	3.0000 76.2	5.9055 150	1.4173 36	2.6772 68	0.08 2	41500 183	0.22	3.1	4.6	53000 236	3	7.79 3.53	1700 7.6	2200
3 3/16	3.1875 80.963	6.2992 160	1.5748 40	2.7559 70	0.08 2	47500 212	0.22	3.1	4.7	60000 270	3.1	9.29 4.22	1700 7.6	2000
3 1/4	3.2500 82.55	6.2992 160	1.5748 40	2.7559 70	0.08 2	47500 212	0.22	3.1	4.7	60000 270	3.1	9.05 4.1	1700 7.6	2000
3 7/16	3.4375 87.313	7.0866 180	1.8110 46	2.9921 76	0.08 2.1	58500 260	0.23	2.9	4.3	72000 320	2.8	14.2 6.45	1700 7.6	1300
	3.4375 87.313	7.0866 180	1.8110 46	2.9921 76	0.08 2.1	64000 285	0.23	2.9	4.3	81500 360	2.8	14.2 6.45	1700 7.6	1700

The designs printed in **bold face** are produced in series.
Information on other designs will be supplied on request.

*) For inner rings which are not axially supported.

Equivalent dynamic load		Equivalent static load	
$P = 1.1 (F_r + Y \cdot F_a)$	[lbs, kN]	$F_a/F_r \leq e$	$P_0 = F_r + Y_0 \cdot F_a$ [lbs, kN]
$P = 1.1 (0.67 \cdot F_r + Y \cdot F_a)$	[lbs, kN]	$F_a/F_r > e$	

P/C must be equal to or less than 0.2 to prevent the inner rings from creeping on the shaft in circumferential direction. Higher values are permissible if the speed is much lower than the limiting speed. Please consult our experts in such cases.

Examples for bearing exchange in plummer block housings

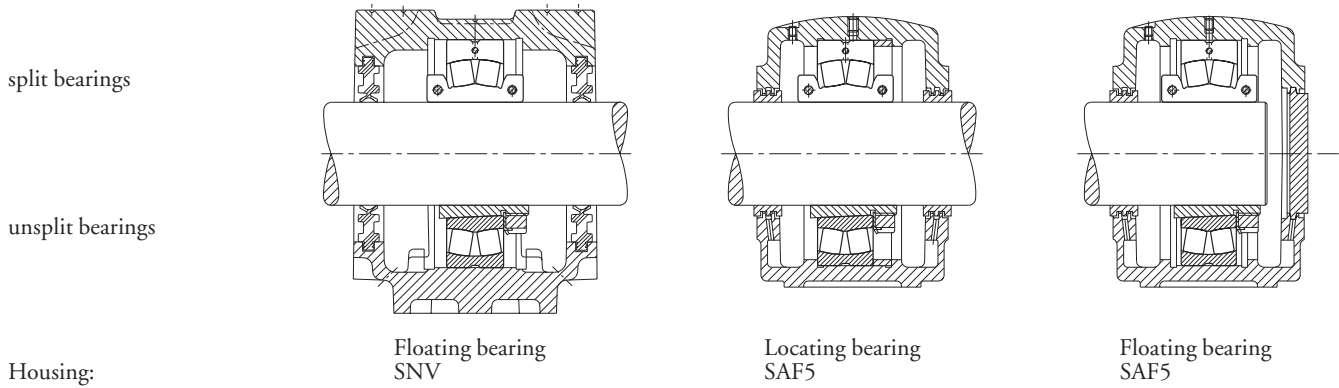

Bolt tightening torque		Code		Can replace unsplit spherical roller bearings with adapter sleeve		Matching plummer block housings**)
Inner ring M_i ft lbs N m	Outer ring M_a ft lbs N m	Bearing		Bearing	Adapter sleeve	
		FAG	FAG			FAG
6 8.5	1.1 1.5	222S.203		22213K	SNW13.203 H313.203	SAF513 SNV120
6 8.5	1.1 1.5	222S.204		22213K	SNW313.204 H313.204	SAF513/2.1/4 SNV120
6 8.5	3 4	222S.207		22215K	SNW15.207 H315.207	SAF515 SNV130
6 8.5	3 4	222S.208		22215K	SNW15.208 H315.208	SAF515/2.1/2 SNV130
6 8.5	3 4	222S.211		22216K	SNW16.211 H316.211	SAF516 SNV140
10 14	6 8.5	222S.215		22217K	SNW17.215 H317.215	SAF517 SNV150
10 14	6 8.5	222S.300		22217K	SNW17.300 H317.300	SAF517/3 SNV150
10 14	6 8.5	222S.303		22218K	SNW18.303 H318.303	SAF518 SNV160
10 14	6 8.5	222S.304		22218K	SNW18.304 H318.304	SAF518/3.1/4 SNV160
10 14	10 14			22220K	SNW20.307 H320.307	SAF520 SNV180
10 14	10 14			22220K	SNW20.307 H320.307	SAF520 SNV180

***) The bearings also fit into housings from other manufacturers provided the inside dimensions are the same. Seals, covers and locating rings for SNV housings, see FAG catalogue WL 41 520

FAG spherical roller bearings

split, in inch dimensions

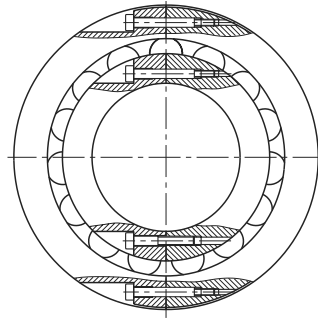

Suffix:

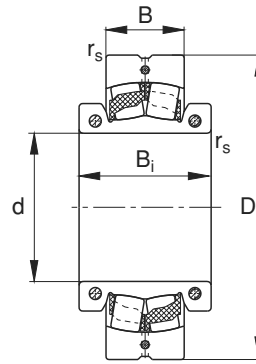

Moulded polyamide cage

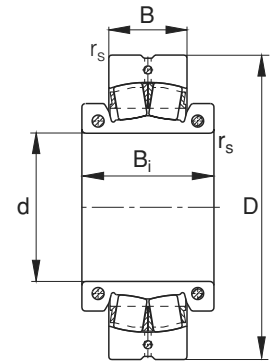

Machined brass cage
MA

Shaft	Dimensions					Load rating · Factor						Mass ≈	Permissible axial load*)	Limiting speed
	d	D	B	B _i	r _s min	C	e	Y	Y	stat.	C ₀			
inch	inch mm					lbs kN		F _a /F _r ≤ e	F _a /F _r > e	lbs kN		lbs kg	lbs kN	min ⁻¹
3 1/2	3.5000	7.0866	1.8110	2.9921	0.08	58500	0.23	2.9	4.3	72000	2.8	13.6	1700	1300
	88.9	180	46	76	2.1	260				320		6.15	7.6	
3 15/16	3.5000	7.0866	1.8110	2.9921	0.08	64000	0.23	2.9	4.3	81500	2.8	13.6	1700	1700
	88.9	180	46	76	2.1	285				360		6.15	7.6	
3 15/16	3.9375	7.8740	2.0866	3.6220	0.08	80000	0.24	2.8	4.2	104000	2.8	19.6	3100	1500
	100.013	200	53	92	2.1	360				465		8.88	13.8	
4	4.0000	7.8740	2.0866	3.6220	0.08	80000	0.24	2.8	4.2	104000	2.8	19.5	3100	1500
	101.6	200	53	92	2.1	360				465		8.83	13.8	
4 3/16	4.1875	8.4646	2.2835	3.8583	0.08	102000	0.25	2.7	4	132000	2.7	24.3	3100	1300
	106.363	215	58	98	2.1	455				585		11	13.8	
4 7/16	4.4375	9.0551	2.5197	4.0945	0.12	120000	0.25	2.7	4	163000	2.7	32.3	3100	1200
	112.713	230	64	104	3	540				720		14.7	13.8	
4 1/2	4.5000	9.0551	2.5197	4.0945	0.12	120000	0.25	2.7	4	163000	2.7	31.8	3100	1200
	114.3	230	64	104	3	540				720		14.4	13.8	
4 15/16	4.9375	9.8425	2.6772	4.3307	0.12	129000	0.26	2.6	3.9	176000	2.6	41.2	3100	850
	125.413	250	68	110	3	585				780		18.7	13.8	
4 15/16	4.9375	9.8425	2.6772	4.3307	0.12	143000	0.26	2.6	3.9	196000	2.6	39.3	3100	1100
	125.413	250	68	110	3	630				880		17.8	13.8	
5	5.0000	9.8425	2.6772	4.3307	0.12	143000	0.26	2.6	3.9	196000	2.6	38.7	3100	1100
	127	250	68	110	3	630				880		17.5	13.8	
5 3/16	5.1875	10.6299	2.8740	4.8031	0.12	166000	0.25	2.7	4	228000	2.6	54.6	5000	1000
	131.763	270	73	122	3	735				1020		24.8	22.2	

The designs printed in **bold face** are produced in series.
Information on other designs will be supplied on request.

*) For inner rings which are not axially supported.

Equivalent dynamic load		Equivalent static load	
$P = 1.1 (F_r + Y \cdot F_a)$	[lbs, kN]	$F_a/F_r \leq e$	$P_0 = F_r + Y_0 \cdot F_a$ [lbs, kN]
$P = 1.1 (0.67 \cdot F_r + Y \cdot F_a)$	[lbs, kN]	$F_a/F_r > e$	

P/C must be equal to or less than 0.2 to prevent the inner rings from creeping on the shaft in circumferential direction. Higher values are permissible if the speed is much lower than the limiting speed. Please consult our experts in such cases.

Examples for bearing exchange in plummer block housings

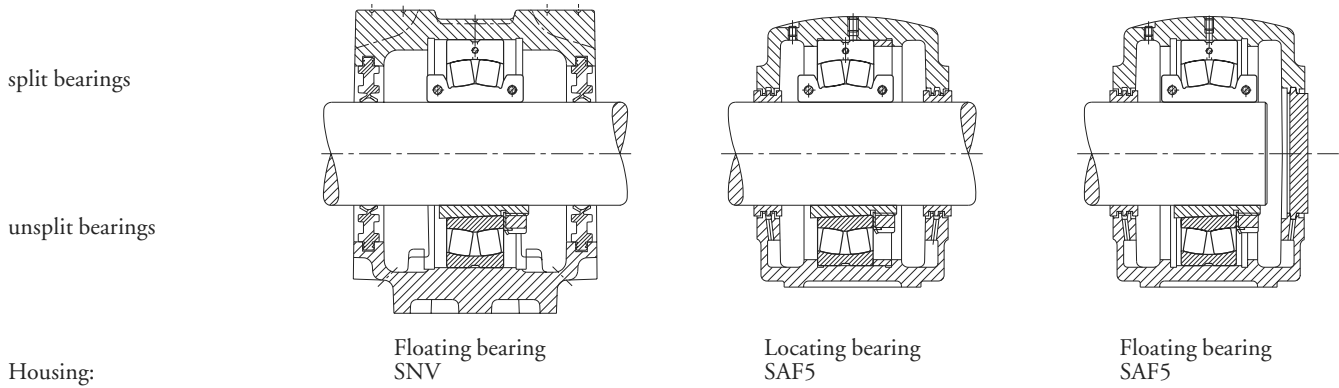

Bolt tightening torque		Code		Can replace unsplit spherical roller bearings with adapter sleeve		Matching plummer block housings**)
Inner ring M_i ft lbs N m	Outer ring M_a ft lbs N m	Bearing FAG	FAG	Bearing	Adapter sleeve	FAG
10 14	10 14		222S.308MA	22220K	SNW20.308 H320.308	SAF520/3.1/2 SNV180
10 14	10 14	222S.308		22220K	SNW20.308 H320.308	SAF520/3.1/2 SNV180
26 35	10 14	222S.315		22222K	SNW22.315 H322.315	SAF522 SNV200
26 35	10 14	222S.400		22222K	SNW22.400 H322.400	SAF522/4 SNV200
26 35	10 14	222S.403		22224K	SNW24.403 H3124.403	SAF524 SNV215 ¹⁾
26 35	10 14	222S.407		22226K	SNW26.407 H3126.407	SAF526 SNV230 ¹⁾
26 35	10 14	222S.408		22226K	SNW26.408 H3126.408	SAF526/4.1/2 SNV230 ¹⁾
26 35	10 14		222S.415MA	22228K	SNW28.415 H3128.415	SAF528 SNV250 ¹⁾
26 35	10 14	222S.415		22228K	SNW28.415 H3128.415	SAF528 SNV250 ¹⁾
26 35	10 14	222S.500		22228K	SNW28.500 H3128.500	SAF528/5 SNV250 ¹⁾
51 69	26 35	222S.503		22230K	SNW30.503 H3130.503	SAF530 SNV270 ¹⁾

**) The bearings also fit into housings from other manufacturers provided the inside dimensions are the same. Seals, covers and locating rings for SNV housings, see FAG catalogue WL 41 520

¹⁾ Housing with eye bolt

FAG spherical roller bearings

split, in inch dimensions

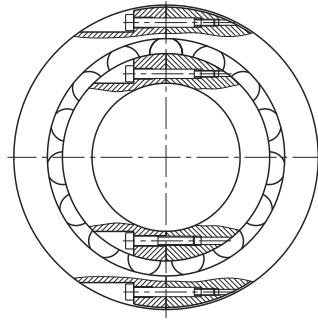

Suffix:

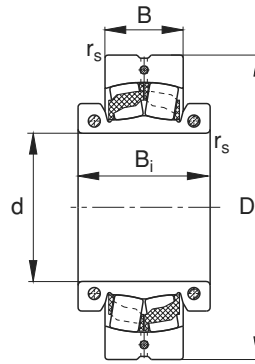

Moulded polyamide cage

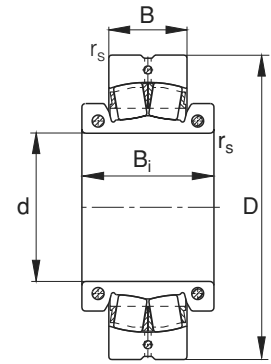

Machined brass cage
MA

Shaft	Dimensions					Load rating · Factor						Mass ≈	Permissible axial load*)	Limiting speed
	d	D	B	B _i	r _s min	C	e	Y	Y	stat.	C ₀			
inch	inch mm					lbs kN		F _a /F _r ≤ e	F _a /F _r > e	lbs kN		lbs kg	lbs kN	min ⁻¹
5 7/16	5.4375	11.4173	3.1496	4.8819	0.12	173000	0.25	2.7	4	240000	2.6	58.4	5000	750
	138.113	290	80	124	3	780				1060		26.5	22.2	
5 1/2	5.4375	11.4173	3.1496	4.8819	0.12	190000	0.25	2.7	4	270000	2.6	63.8	5000	950
	138.113	290	80	124	3	850				1200		28.9	22.2	
5 1/2	5.5000	9.4488	2.3622	4.1732	0.08	100000	0.22	3.1	4.6	153000	3	30.2	3100	900
	139.7	240	60	106	2.1	450				680		13.7	13.8	
5 15/16	5.5000	11.4173	3.1496	4.8819	0.12	190000	0.25	2.7	4	270000	2.6	63.1	5000	950
	139.7	290	80	124	3	850				1200		28.6	22.2	
6	5.9375	12.2047	3.3858	5.0394	0.16	216000	0.26	2.6	3.9	310000	2.6	77.9	5000	900
	150.813	310	86	128	4	965				1370		35.4	22.2	
6	6.0000	12.2047	3.3858	5.0394	0.16	216000	0.26	2.6	3.9	310000	2.6	77.1	5000	900
	152.4	310	86	128	4	965				1370		35	22.2	
6 7/16	6.4375	11.4173	2.9528	4.7244	0.08	173000	0.23	2.9	4.3	285000	2.8	55.6	5000	700
	163.513	290	75	120	2.1	780				1250		25.2	22.2	
6 7/16	6.4375	11.8110	3.7795	5.5118	0.08	186000	0.29	2.3	3.5	275000	2.3	81.6	5000	670
	163.513	300	96	140	2.1	830				1220		37	22.2	
6 7/16	6.4375	12.5984	3.3858	5.1575	0.16	216000	0.26	2.6	3.9	310000	2.6	80.4	5000	900
	163.513	320	86	131	4	965				1370		36.5	22.2	
6 1/2	6.5000	12.5984	3.3858	5.1575	0.16	216000	0.26	2.6	3.9	310000	2.6	79.5	5000	900
	165.1	320	86	131	4	965				1370		36.1	22.2	
6 15/16	6.9375	13.3858	3.6220	5.5905	0.16	255000	0.25	2.7	4	365000	2.7	91.1	5000	800
	176.213	340	92	142	4	1140				1630		41.7	22.2	
7	7.0000	11.4173	2.9528	4.7244	0.08	173000	0.23	2.9	4.3	285000	2.8	46.5	5000	700
	177.8	290	75	120	2.1	780				1250		21.1	22.2	

The designs printed in **bold face** are produced in series.
Information on other designs will be supplied on request.

*) For inner rings which are not axially supported.

Equivalent dynamic load		Equivalent static load	
$P = 1.1 (F_r + Y \cdot F_a)$	[lbs, kN]	$F_a/F_r \leq e$	$P_0 = F_r + Y_0 \cdot F_a$ [lbs, kN]
$P = 1.1 (0.67 \cdot F_r + Y \cdot F_a)$	[lbs, kN]	$F_a/F_r > e$	

P/C must be equal to or less than 0.2 to prevent the inner rings from creeping on the shaft in circumferential direction. Higher values are permissible if the speed is much lower than the limiting speed. Please consult our experts in such cases.

Examples for bearing exchange in plummer block housings

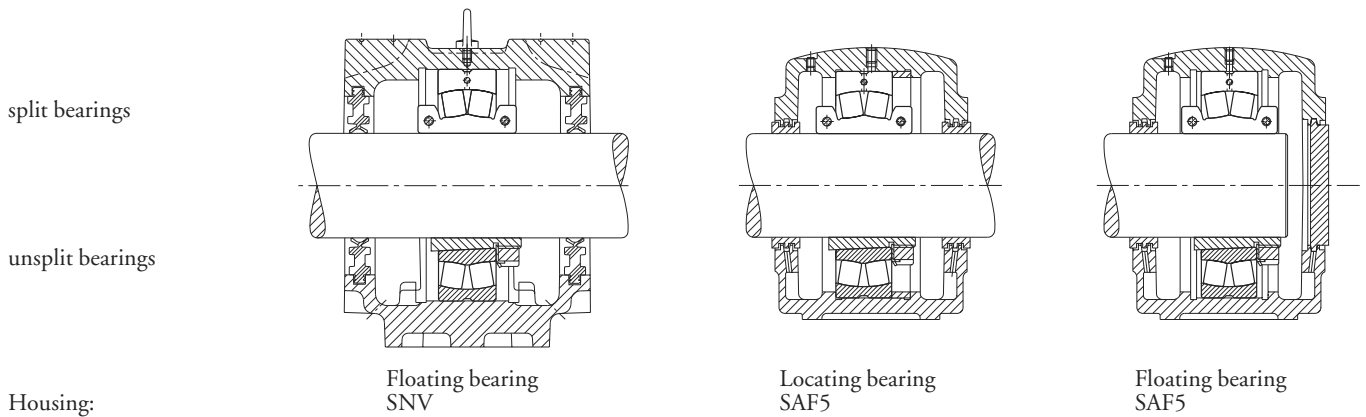

Bolt tightening torque

Inner ring
 M_i
 ft lbs
 N m

Outer ring
 M_a
 ft lbs
 N m

Code

Bearing

FAG FAG

Can replace unsplit spherical roller bearings with adapter sleeve

Bearing Adapter sleeve

Matching plummer block housings**)

FAG

51 69	26 35		222S.507MA	22232K	SNW32.507 H3132.507	SAF532 SNV290
51 69	26 35	222S.507		22232K	SNW32.507 H3132.507	SAF532 SNV290
26 35	6 8.5		230S.508MA	23032K	SNP3032.508 H3032.508	SAF032K/5.1/2
51 69	26 35	222S.508		22232K	SNW32.508 H3132.508	SAF532/5.1/2 SNV290
51 69	26 35	222S.515		22234K	SNW34.515 H3134.515	SAF534
51 69	26 35	222S.600		22234K	SNW34.600 H3134.600	SAF534/6
51 69	10 14	230S.607		23038K	SNP3038.607 H3038.607	SAF038K/6.7/16
51 69	26 35		231S.607MA	23136K	SNP3136.607 H3136.607	SDAF3136K/6.7/16
51 69	26 35	222S.607		22236K	SNW36.607 H3136.607	SAF536
51 69	26 35	222S.608		22236K	SNW36.608 H3136.608	SAF536/6.1/2
51 69	26 35	222S.615		22238K	SNW38.615 H3138.615	SAF538
51 69	10 14	230S.700		23038K	SNP3038.700 H3038.700	SAF038K/7

***) The bearings also fit into housings from other manufacturers provided the inside dimensions are the same. Seals, covers and locating rings for SNV housings, see FAG catalogue WL 41 520

FAG spherical roller bearings

split, in inch dimensions

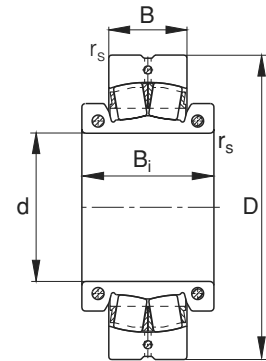
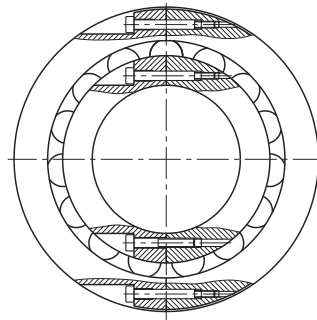

Machined brass cage
(no suffix if $d > 7$ inch)

Shaft	Dimensions					Load rating · Factor						Mass ≈	Permissible axial load*)	Limiting speed
	d	D	B	B _i	r _s min	C	e	Y	Y	stat. C ₀	Y ₀			
inch	inch mm					lbs kN	F _a /F _r ≤ e	F _a /F _r > e		lbs kN		lbs kg	lbs kN	min ⁻¹
7 3/16	7.1875 182.563	14.1732 360	3.8583 98	6.0630 154	0.16 4	255000 1140	0.25	2.7	4	365000 1630	2.7	116 52.6	5000 22.2	600
7 1/2	7.5000 190.5	15.7480 400	4.2520 108	6.3779 162	0.16 4	300000 1340	0.25	2.7	4	425000 1900	2.6	162 73.3	7200 32	560
7 15/16	7.9375 201.613	15.7480 400	4.2520 108	6.3779 162	0.16 4	300000 1340	0.25	2.7	4	425000 1900	2.6	152 69	7200 32	560
8	8.0000 203.2	15.7480 400	4.2520 108	6.3779 162	0.16 4	300000 1340	0.25	2.7	4	425000 1900	2.6	151 68.4	7200 32	560
8 1/2	8.5000 215.9	14.1732 360	3.6220 92	6.1417 156	0.12 3	250000 1100	0.23	2.9	4.3	415000 1830	2.8	121 54.7	7200 32	560
9	9.0000 228.6	14.1732 360	3.6220 92	6.2992 160	0.12 3	250000 1100	0.23	2.9	4.3	415000 1830	2.8	108 49.2	7200 32	560
9 1/2	9.5000 241.3	15.7480 400	4.0945 104	6.2992 160	0.16 4	275000 1220	0.22	3	4.5	480000 2120	3	125 56.8	7200 32	560
10	10.0000 254	16.5354 420	4.1732 106	6.6929 170	0.16 4	325000 1460	0.23	3	4.4	550000 2450	2.9	146 66.4	7200 32	500
11	11.0000 279.4	18.1102 460	4.6457 118	6.9291 176	0.16 4	360000 1600	0.22	3	4.5	620000 2800	3	211 96	7200 32	480
	11.0000 279.4	19.6850 500	6.2992 160	8.5827 218	0.2 5	520000 2320	0.29	2.3	3.5	880000 3900	2.3	352 160	9900 44	400

The designs printed in **bold face** are produced in series.
Information on other designs will be supplied on request.

*) For inner rings which are not axially supported.

Equivalent dynamic load			Equivalent static load		
$P = 1.1 (F_r + Y \cdot F_a)$	[lbs, kN]	$F_a/F_r \leq e$	$P_0 = F_r + Y_0 \cdot F_a$	[lbs, kN]	
$P = 1.1 (0.67 \cdot F_r + Y \cdot F_a)$	[lbs, kN]	$F_a/F_r > e$			

P/C must be equal to or less than 0.2 to prevent the inner rings from creeping on the shaft in circumferential direction. Higher values are permissible if the speed is much lower than the limiting speed. Please consult our experts in such cases.

Examples for bearing exchange in plummer block housings

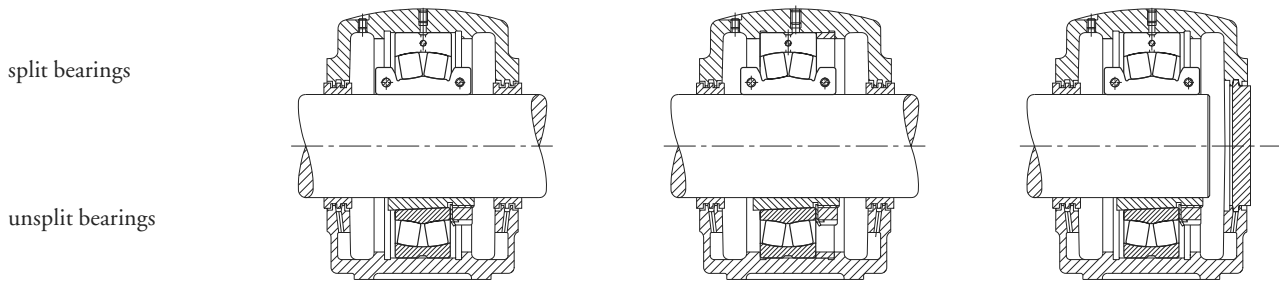

Housing: Floating bearing SAF5 Locating bearing SAF5 Floating bearing SAF5

Bolt tightening torque		Code	Can replace unsplit spherical roller bearings with adapter sleeve		Matching plummer block housings**)
Inner ring M_i ft lbs N m	Outer ring M_a ft lbs N m	Bearing FAG	Bearing	Adapter sleeve	FAG
51 69	26 35	222S.703	22240K	SNW40.703 H3140.703	SAF540
88 120	51 69	222S.708	22244K	SNW44.708 H3144X.708	SAF544/7.1/2
88 120	51 69	222S.715	22244K	SNW44.715 H3144X.715	SAF544
88 120	51 69	222S.800	22244K	SNW44.800 H3144X.800	SAF544/8
88 120	26 35	230S.808	23048K	SNP3048.808 H3048.808	SAF048K/8.1/2
88 120	26 35	230S.900	23048K	SNP3048.900 H3048.900	SAF048K/9
88 120	51 69	230S.908	23052K	SNP3052.908 H3052X.908	SAF052K/9.1/2
88 120	26 35	230S.1000	23056K	SNP3056.1000 H3056.1000	SAF056K/10
88 120	51 69	230S.1100	23060K	SNP3060.1100 H3060.1100	SDAF060K/11
140 190	88 120	231S.1100	23160K	SNP3160.1100 H3160HG.1100	SDAF3160K/11

**) The bearings also fit into housings from other manufacturers provided the inside dimensions are the same.

FAG spherical roller bearings

split, in inch dimensions

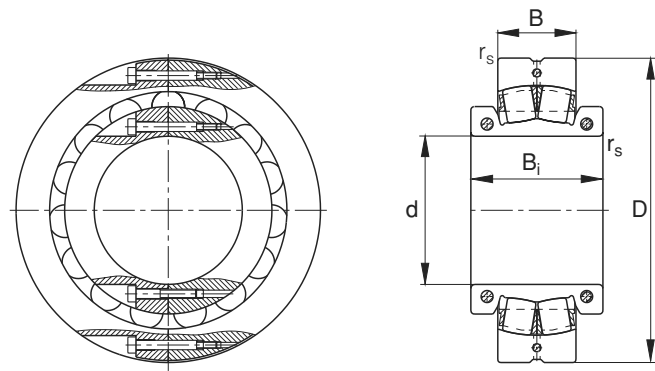

Machined brass cage
(no suffix if $d > 7$ inch)

Shaft	Dimensions					Load rating · Factor						Mass ≈	Permissible axial load*)	Limiting speed
	d	D	B	B _i	r _s min	dyn.		stat.		C ₀	Y ₀			
inch	inch mm					lbs kN	e	Y	Y	lbs kN		lbs kg	lbs kN	min ⁻¹
12	12.0000	18.8976	4.7638	7.3228	0.16	425000	0.23	2.9	4.3	720000	2.8	231	7200	430
	304.8	480	121	186	4	1860				3200		105	32	
12	12.0000	21.2598	6.9291	8.8583	0.2	620000	0.29	2.3	3.4	1060000	2.3	397	13500	360
	304.8	540	176	225	5	2750				4750		180	60	
13	13.0000	21.2598	5.2756	8.0709	0.2	530000	0.22	3	4.5	930000	2.9	363	13500	380
	330.2	540	134	205	5	2360				4150		165	60	
13	13.0000	23.6220	7.5591	10.6299	0.2	880000	0.3	2.3	3.3	1530000	2.2	628	13500	300
	330.2	600	192	270	5	3900				6800		285	60	
14	14.0000	22.0472	5.3150	8.5827	0.2	570000	0.22	3.1	4.6	1040000	3	373	13500	380
	355.6	560	135	218	5	2550				4650		169	60	
14	14.0000	24.4094	7.6378	10.6299	0.2	880000	0.3	2.3	3.4	1560000	2.2	655	13500	300
	355.6	620	194	270	5	3900				6950		297	60	

The designs printed in **bold face** are produced in series.
Information on other designs will be supplied on request.

*) For inner rings which are not axially supported.

Equivalent dynamic load		Equivalent static load	
$P = 1.1 (F_r + Y \cdot F_a)$	[lbs, kN]	$F_a/F_r \leq e$	$P_0 = F_r + Y_0 \cdot F_a$ [lbs, kN]
$P = 1.1 (0.67 \cdot F_r + Y \cdot F_a)$	[lbs, kN]	$F_a/F_r > e$	

P/C must be equal to or less than 0.2 to prevent the inner rings from creeping on the shaft in circumferential direction. Higher values are permissible if the speed is much lower than the limiting speed. Please consult our experts in such cases.

Examples for bearing exchange in plummer block housings

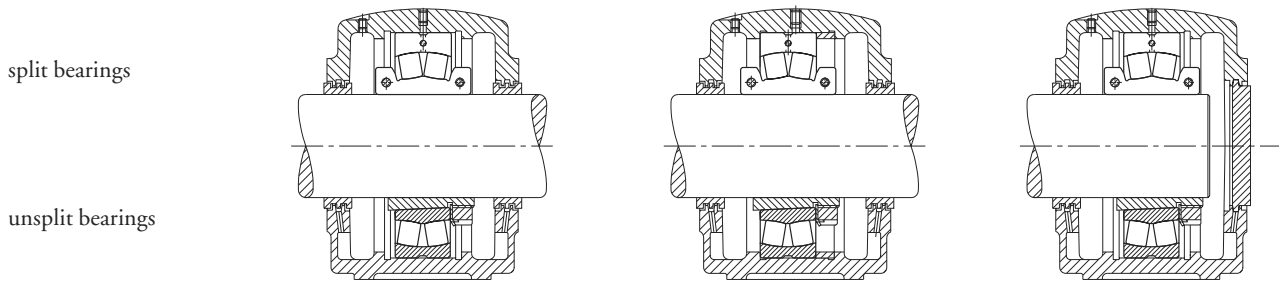

Housing: Floating bearing SDAF5 Locating bearing SDAF5 Floating bearing SDAF5

Bolt tightening torque		Code	Can replace unsplit spherical roller bearings with adapter sleeve		Matching plummer block housings**)
Inner ring M_i ft lbs N m	Outer ring M_a ft lbs N m	Bearing FAG	Bearing	Adapter sleeve	FAG
88 120	51 69	230S.1200	23064K	SNP3064.1200 H3064HG.1200	SDAF064K/12
212 295	88 120	231S.1200	23164K	SNP3164.1200 H3164HG.1200	SDAF3164K/12
212 295	51 69	230S.1300	23072K	SNP3072.1300 H3072HG.1300	SDAF072K/13
212 295	88 120	231S.1300	23172K	SNP3172.1300 H3172HG.1300	SDAF3172K/13
212 295	51 69	230S.1400	23076K	SNP3076.1400 H3076HG.1400	SDAF076K/14
212 295	51 69	231S.1400	23176K	SNP3176.1400 H3176HG.1400	SDAF3176K/14

***) The bearings also fit into housings from other manufacturers provided the inside dimensions are the same.

Cost reduction due to shorter downtimes

Example 1: Exhaust gas ventilator

Existing bearing with sleeve: 22226EK.C3+H3126 at drive end and opposite end
 FAG split bearing: 222SM115T

Required steps in bearing mounting and dismounting	
Unsplit bearing 22226EK.C3 + H3126	Split bearing 222SM115T
Disassemble couplings	not required
Loosen fastening bolts (housing bases)	not required
Remove coupling (mounted with feather key and shrink fit)	not required
Remove bearing at drive end (replaced as a precaution)	not required
Remove bearing at opposite end	yes
Install new bearing at opposite end	yes
Install new bearing at drive end	not required
Assembly in reverse order	–

Cost factors	Unsplit bearing 22226EK.C3 + H3126	Split bearing 222SM115T
Downtime	14 hours	3 hours
Downtime cost (disruption of production) (€ 20,000.00/h of ventilator downtime)	14 x € 20 000.00 = € 280 000.00	3 x € 20 000.00 = € 60 000.00
Man hours (2 men working 14 h each, 2 men working 3 h each) (hourly rate: € 20.00)	2 x 14 = 28 h 28 x € 20.00 = € 560.00	2 x 3 = 6 h 6 x € 20.00 = € 120.00
Alignment (hourly rate: € 35.00)	3 hours 3 x € 35.00 = € 105.00	not required
Crane rental	4 x € 105.00 = € 420.00	not required
Replacement bearing (drive end) as a precaution	€ 330.00	not required
Replacement bearing (opposite end)	€ 330.00	€ 820.00
Total cost of bearing replacement	€ 281 745.00	€ 60 940.00
Cost saved by using FAG split spherical roller bearings	€ 220 805.00	

Cost reduction due to shorter downtimes

Example 2: Exhaust ventilator

Existing bearing with sleeve: 23152K.MB + H3152XHG at drive end and opposite end
 FAG split bearing: 231SM240MA

Required steps in bearing mounting and dismounting		
Unsplit bearing 23152K.MB + H3152XHG		Split bearing 231SM240MA
Disassemble couplings at transmission input and output ends		not required
Loosen connection between foundation and electric motor		not required
Loosen fastening bolts (housing bases)		not required
Remove cover for easier lifting		not required
Use loops to suspend impeller		not required
Lift rotor using a crane		not required
Remove transmission using a crane (access to coupling)		not required
Remove coupling (mounted with feather key and shrink fit)		not required
Remove bearing at drive end (replaced as a precaution)		no
Remove bearing at opposite end		yes
Install new bearing at opposite end		yes
Install new bearing at drive end		not required
Assembly in reverse order		–
Cost factors		
	Unsplit bearing 23152K.MB + H3152XHG	Split bearing 231SM240MA
Downtime	36 h	6 h
Downtime cost (€ 1,350.00/h)	36 x € 1 350.00 = € 48 600.00	6 x € 1 350.00 = € 8 100.00
Man hours (3 men working 18 h each, 2 men working 6 h each) (hourly rate: € 20.00)	3 x 18 = 54 h 54 x € 20.00 = € 1 080.00	2 x 6 = 12 h 12 x € 20.00 = € 240.00
Alignment (hourly rate € 35.00)	3 hours 3 x € 35.00 = € 105.00	not required
Crane rental	24 x € 105.00 = € 2 520.00	not required
Replacement bearing (drive end)	€ 2 200.00	not required
Replacement bearing (opposite end)	€ 2 200.00	€ 8 800.00
Hydraulic nut RKP 260	€ 2 510.00	not required
Total cost of bearing replacement	€ 59 215.00	€ 17 140.00
Cost saved by using FAG split spherical roller bearings	€ 42 075.00	

Cost reduction due to shorter downtimes

Firm/contact partner
Application
Existing bearing with sleeve
FAG split bearing

Required steps in bearing mounting and dismounting	Unsplit bearing	Split bearing
Disassemble drive unit (transmission, belt/chain, electric motor)		not required
Remove coupling halves/pulley/sprocket		not required
Support rotor on trestles	not required	
Detach housing bases		not required
Lift rotor		not required
Remove housing cover		
Remove housing base		not required
Clean components, install and inspect new bearing		
Assemble housing		
Align housing relative to shaft		not required
Mount housing on foundation		not required
Mount coupling halves/pulley/sprocket		not required
Assemble drive unit (transmission, belt/chain, electric motor)		not required
Align drive train		not required
Total downtime in hours		

Cost comparison	Unsplit bearing	Split bearing
Downtime cost		
Lifting equipment		
Special mounting tools (e.g. hydraulic nut)		
Labour cost (man hours)		
Replacement bearing (split or unsplit with adapter sleeve)		
Alignment (equipment and labour cost)		
Total cost of bearing replacement		

Costs saved by using FAG split spherical roller bearings

FAG Kugelfischer AG

Postfach 1260

D-97419 Schweinfurt

Georg-Schäfer-Strasse 30

97421 Schweinfurt

Phone: +49 9721 91-0

Fax: +49 9721 913435

www.fag.com

Every care has been taken to ensure the correctness of the information contained in this publication but no liability can be accepted for any errors or omissions. We reserve the right to make changes in the interest of technical progress.

© by FAG 2004.

This publication or parts thereof may not be reproduced without our permission.

WL 43 165 EA